



CITY OF
Ames™

**2020 Supplemental Specifications
to the
Iowa Statewide Urban Design
and Specifications (SUDAS)**

Public Works Department
Engineering Division
515 Clark Avenue
Ames, IA 50010

City of Ames Supplemental Specifications to SUDAS (2020 Edition)

Date of Last Revision: 2-27-20

Table of Contents

Division 1: General Provisions and Covenants	5
Section 1010: General Conditions	5
1.03 DEFINITIONS AND TERMS	5
Section 1040: Scope of work	5
1.06 INCREASE OR DECREASE OF WORK.....	5
1.09 CHANGED SITE CONDITIONS	6
1.10 DISPUTED CLAIMS FOR EXTRA COMPENSATION	6
1.11 DELAYS CAUSED BY THE JURISDICTION.....	6
Section 1050: Control of work.....	6
1.12 SALVAGE.....	6
Section 1060: Control of Materials.....	6
1.04 STORAGE OF MATERIALS	6
Section 1070: Legal Relations and Responsibility to the Public.....	6
2.01 SANITATION	6
2.02 CONVENIENCE AND SAFETY.....	6
2.07 PROTECTION OF ABOVEGROUND AND UNDERGROUND FACILITIES.....	6
Add: 2.16 GARBAGE SERVICES.....	7
Section 1080: Prosecution and Progress	7
1.01 SUBLETTING OR ASSIGNMENT OF CONTRACT	7
1.04 PRECONSTRUCTION CONFERENCE	7
1.06 WEEKLY RECORD OF WORKING DAYS.....	7
1.10 CONTRACTOR’S EMPLOYEES, METHODS, AND EQUIPMENT.....	7
Division 2: Earthwork	7
Section 2010: Earthwork, Subgrade, and Subbase.....	7
1.08 MEASUREMENT AND PAYMENT	7
2.01 TOPSOIL	7
2.04 FOUNDATION MATERIALS.....	7
3.04 EMBANKMENT CONSTRUCTION	7
3.06 SUBGRADE PREPARATION.....	8
3.08 SUBBASE	8
3.09 FIELD QUALITY CONTROL.....	8
Division 3: Trench and Trenchless Construction	8
Section 3010: Trench Excavation and Backfill.....	8
1.08 MEASUREMENT AND PAYMENT	8
2.01 MATERIALS EXCAVATED FROM A TRENCH	8
3.05 PIPE BEDDING AND BACKFILL	8
3.06 TRENCH COMPACTION TESTING.....	8
Section 3020: Trenchless Construction.....	9

3.04 TRENCHLESS INSTALLATION	8
Division 4: Sewers and Drains	9
Section 4010: Sanitary Sewers.....	9
2.01 SANITARY SEWER (Gravity Mains)	9
2.04 SANITARY SEWER SERVICES	9
3.02 GRAVITY SEWER INSTALLATION	9
3.06 SANITARY SEWER SERVICE STUBS	9
Section 4020: Storm Sewers	9
1.07 SPECIAL REQUIREMENTS.....	9
3.02 PIPE INSTALLATION	9
Section 4050: Pipe Rehabilitation.....	9
1.07 SPECIAL REQUIREMENTS.....	9
Section 4060: Cleaning, Inspection, and Testing of Sewers	10
2.01 TESTING EQUIPMENT	10
3.01 CLEANING	10
3.03 VIDEO INSPECTION	10
Division 5: Water Mains and Appurtenances	10
Section 5010: Pipe and Fittings	10
1.08 MEASUREMENT AND PAYMENT	10
2.04 CONCRETE THRUST BLOCKS	10
2.05 PIPELINE ACCESSORIES.....	10
2.07 WATER SERVICE PIPE AND APPURTENANCES.....	10
3.01 PIPE INSTALLATION	10
3.06 TRACER SYSTEM INSTALLATION	10
3.07 CONFLICTS	11
Figure 5010.102 (WM-102).....	11
Section 5020: Valves, Fire Hydrants, and Appurtenances.....	11
1.08 MEASUREMENT AND PAYMENT	11
2.01 VALVES.....	11
2.02 FIRE HYDRANT ASSEMBLY	11
2.03 APPURTENANCES.....	11
3.03 FIRE HYDRANT	12
3.04 ADJUSTMENT OF EXISTING VALVE BOX OR FIRE HYDRANT.....	12
Figure 5020.201 (WM-201).....	12
Section 5030: Testing and Disinfection	12
1.07 SPECIAL REQUIREMENTS.....	12
3.05 PRESSURE AND LEAK TESTING	12
Division 6: Structures for Sanitary and Storm Sewers.....	12
Section 6010: Structures for Sanitary and Storm Sewers.....	12
2.02 PRECAST	12
2.03 CAST-IN-PLACE.....	12
2.09 MANHOLE OR INTAKE ADJUSTMENT RINGS (Grade Rings).....	12
2.10 CASTINGS (Ring, Cover, Grate, and Extensions).....	13

2.11 ADDITIONAL MATERIALS FOR SANITARY SEWER MANHOLES.....	13
Delete: 2.13 STEPS (Steps are not allowed.).....	13
3.02 ADDITIONAL REQUIREMENTS FOR CAST-IN-PLACE CONCRETE STRUCTURES.....	13
3.05 CONNECTION TO EXISTING MANHOLE OR INTAKE.....	13
Figure SW-514.....	13
Division 7: Streets and Related Work	13
Section 7010: Portland Cement Concrete Pavement.....	13
1.07 SPECIAL REQUIREMENTS.....	13
3.02 PAVEMENT CONSTRUCTION.....	13
3.03 CURB AND GUTTER CONSTRUCTION.....	14
3.07 QUALITY CONTROL.....	14
Figure 7010.102 (PV-102).....	14
Section 7011: Portland Cement Concrete Overlays.....	14
1.08 MEASUREMENT AND PAYMENT.....	14
Section 7020: Hot Mix Asphalt Pavement.....	15
1.07 SPECIAL REQUIREMENTS.....	15
3.01 HMA PAVEMENT.....	15
3.02 BASE WIDENING.....	15
3.05 PAVEMENT SMOOTHNESS.....	15
Section 7030: Sidewalks, Shared Use Paths, and Driveways.....	15
1.07 SPECIAL REQUIREMENTS.....	15
2.01 PORTLAND CEMENT CONCRETE.....	15
2.07 DETECTABLE WARNINGS.....	15
3.04 PCC SIDEWALKS, SHARED USE PATHS, AND DRIVEWAYS.....	15
3.10 CLEANING.....	16
Figure 7030.101.....	17
Figure 7030.204.....	17
Figure 7030.205.....	17
Figure 7030.206.....	17
Figure 7030.207.....	17
Section 7040: Pavement Rehabilitation.....	17
1.08 MEASUREMENT AND PAYMENT.....	17
Division 8: Traffic Control	17
Section 8010: Traffic Signals.....	17
2.01 UNDERGROUND.....	17
2.02 DETECTION.....	17
2.03 COMMUNICATIONS.....	17
2.04 CABINET AND CONTROLLER.....	17
2.05 POLES, HEADS, AND SIGNS.....	17
Figure 8010.104.....	18
Section 8020: Pavement Markings.....	18
2.01 MATERIALS.....	17

3.02 CONSTRUCTION.....	17
Section 8030: Temporary Traffic Control.....	19
1.03 SUBMITTALS	19
3.01 INSTALLATION	19
3.03 QUALITY CONTROL.....	19
Division 9: Site Work and Landscaping.....	19
Section 9010: Seeding.....	19
1.03 SUBMITTALS	19
1.08 MEASUREMENT AND PAYMENT	19
3.04 CONVENTIONAL SEEDING	19
3.05 HYDRAULIC SEEDING.....	19
Section 9020: Sodding	19
1.03 SUBMITTALS	19
1.08 MEASUREMENT AND PAYMENT	19
3.01 PREPARATION OF SODBED	19
Section 9030: Plant Material and Planting.....	20
1.03 SUBMITTALS	20
Section 9040: Erosion and Sediment Control	20
1.08 MEASUREMENT AND PAYMENT	20
2.18 INLET PROTECTION	20
3.05 COMPOST BLANKETS.....	20
3.09 WATTLES.....	20
Division 11: Miscellaneous	20
Section 11,050: Concrete Washout.....	20
2.01 CONCRETE WASHOUT.....	20

Division 1: General Provisions and Covenants

Section 1010: General Conditions

1.03 DEFINITIONS AND TERMS

Working Day. Delete: “Saturdays” **Add:** Saturdays will not be excluded from working day counts if the contractor is working.

Add: Major Item of Work. Any contract item (pay item) for which the original contract amount plus authorized additions is more than 10% of the original contract sum, or \$25,000, whichever is less.

Section 1040: Scope of work

1.06 INCREASE OR DECREASE OF WORK

B. Delete and Replace with the Following: Unless such alterations, increases, or decreases materially change the character of the work to be performed or the cost thereof, the altered work shall be paid for at the same unit prices as other parts of the work.

Quantity changes, for major items as defined by COA Supplemental Specification 1010.1.03, amounting to 20% or less of the total bid for an item shall not affect the unit price of that item.

When a major item of work, is increased in excess of 120% or decreased below 80% of the original contract quantity. Any allowance for an increase in quantity shall apply only to that portion in excess of 120% of the original contract item quantity. The adjustment in unit price, excluding profit, for an under run in excess of 20% will be computed on the difference between the actual quantity and 80% of the original contract quantity.

EXAMPLE:

If 100 units are in a contract and the item meets the major item definition and only 50 units are installed. The difference between 80% of the contract quantity and the actual installed quantity (50%) is 30 units. 20 units will be paid at the contract price

30 units will be paid at a new, agreed to, unit price.

If, however, the character of the work or the unit costs thereof is materially changed, due to unforeseen events, an allowance shall be made on such basis as may have been agreed to in advance of the performance of the work.

1.09 CHANGED SITE CONDITIONS

B. Compensation:

Add: 3. Under no circumstances will payment for down time be made by the City of Ames as project field issues are being resolved. The City of Ames will take all necessary action to resolve issues in a timely manner.

1.10 DISPUTED CLAIMS FOR EXTRA COMPENSATION

A. Basis of Claim for Extra Compensation:

Add: 6. Under no circumstances will payment for down time be made by the City of Ames as project field issues are being resolved. The City of Ames will take all necessary action to resolve issues in a timely manner.

1.11 DELAYS CAUSED BY THE JURISDICTION

Add: Under no circumstances will payment for down time be made by the City of Ames as project field issues are being resolved. The City of Ames will take all necessary action to resolve issues in a timely manner.

Section 1050: Control of work

1.12 SALVAGE

A. Delete and Replace with the following: All manhole and intake castings, hydrants, and valves shall be carefully salvaged and returned to the City of Ames.

Section 1060: Control of Materials

1.04 STORAGE OF MATERIALS

Add: On contracts for which the contract sum is \$10,000 or more, payments may be allowed at the discretion of the Engineer.

Section 1070: Legal Relations and Responsibility to the Public

2.01 SANITATION

Add: If the duration of the project, in any phase, is 72 hours or more, on-site restroom facilities shall be provided. No additional payment will be made, and any costs shall be incidental.

2.02 CONVENIENCE AND SAFETY

B. Protection of Workers and the Public:

Delete: “when exposed to traffic or construction equipment in the right-of-way.” **and Replace with:** “within the construction zone, no exceptions.”

2.07 PROTECTION OF ABOVEGROUND AND UNDERGROUND FACILITIES

Add: E. The City of Ames performs locates for utility services (water and sewer) as these services, in the City of Ames, are owned by the property owner, not the City of Ames. Utility service locates for water and sewer are courtesy locates and the contractor is solely responsible for determining the exact location of all utility service connections. The City of Ames does not assume responsibility for the exactness of these courtesy locates and any damage caused by a contractor shall be immediately repaired at the Contractor’s expense by a plumber licensed to do work in the City of Ames.

Add: F. Potholing activities within pavement: Core holes shall be replaced with a minimum size patch of 4’x4’ or full sidewalk/shared use path panel unless otherwise approved by the Engineer, and the patch shall be Class C concrete. Class M concrete may be used with approval of the Engineer. Asphalt patches may be utilized only on asphalt/sealcoat streets and only with approval of the Engineer. Asphalt patches shall be a minimum of 4’x4’ and the mix shall meet SUDAS Specification 7020. The core hole plug is not to be utilized to fill the hole. Pothole locations are to be filled and maintained with granular material immediately after use to ensure that the hole does not present a danger.

Add: G. Potholing activities outside pavement: Immediately after use, holes outside of the pavement shall be backfilled with sand to no closer than 8” from the top of the existing surrounding soil. These areas shall then be immediately filled with topsoil, seeded, and maintained at grade until permanent growth is fully established.

Add: H. Potholing activities within sidewalks and pedestrian ramps: If potholing activities affect any portion of a pedestrian ramp, any elements of the ramp that do not meet current ADA standards shall be replaced and brought into ADA compliance in accordance with Supplemental Specification Section 7030. The affected panels shall be removed and replaced with class C concrete. Class M concrete may be used with approval of the Engineer.

Add: I. Temporary ADA Compliance: Potholes shall be patched or temporarily made ADA compliant within 48 hours of potholing. All pothole locations shall be immediately filled with granular material and maintained such that there is no danger to the public. Protection in sidewalk areas shall meet ADA requirements for trip hazards. If the protection cannot

meet ADA requirements, a fully compliant pedestrian detour shall be set up according to the City of Ames Standard Traffic Control Plans until the panels are replaced.

Add: 2.16 GARBAGE SERVICES The contractor shall coordinate with local trash services for trash collection during the project with notification of project impacts to trash collection. No additional payment will be made unless otherwise specified in the contract documents.

Section 1080: Prosecution and Progress

1.01 SUBLETTING OR ASSIGNMENT OF CONTRACT

A. Work by Contractor:

1. **Delete:** “30%” **and Replace with:** “50%”

2. **Delete:** “30%” **and Replace with:** “50%”

Add: 4. Any and all service work shall be performed by a plumber licensed with the City of Ames and in accordance with the Ames Municipal Plumbing Code. The contractor shall coordinate the work to be done so that it does not impede the progress of the project as a whole.

Add: 5. All traffic signal service work shall be performed with a licensed IMSA Signal Level II technician onsite.

1.04 PRECONSTRUCTION CONFERENCE

Add: The contractor shall provide a minimum of 5 business days’ notice to schedule a preconstruction meeting. No work or utility locates shall take place until the preconstruction conference has been held. Work shall commence no more than one month after the preconstruction meeting.

1.06 WEEKLY RECORD OF WORKING DAYS

B. Working days will be charged under the following circumstances:

2. After Commencement of Work:

Add: “Saturdays,” **prior to “Sundays” in the last sentence of the 2nd paragraph.**

Delete: As an incentive to the Contractor to expedite the work, working days will not be charged for Saturdays that the Contractor does work, unless a mandatory six-day work week is specified in the contract documents.

1.10 CONTRACTOR’S EMPLOYEES, METHODS, AND EQUIPMENT

B. Workers:

Add: 3. When working in the City of Ames, shirts shall be worn at all times. Clothing with profane or offensive words or designs are not allowed. Workers wearing profane or offensive words or designs must leave the construction site until wearing clothing that is deemed acceptable by City of Ames staff.

Division 2: Earthwork

Section 2010: Earthwork, Subgrade, and Subbase

1.08 MEASUREMENT AND PAYMENT

F. Below Grade Excavation (Core Out):

2. Payment:

Delete: “existing embankments or following proof rolling operations.” **and Replace with:** “embankments constructed as part of the project or once the grade has been approved following a successful proof rolling test.”

L. Compaction Testing:

1. **Delete and Replace with the following:** The contractor will be responsible for compaction testing and payment for testing unless otherwise specified in the contract documents.

Add: 4. Work shall not progress until all required compaction testing reports are submitted to the Jurisdiction by the Contractor, or their testing Subcontractor, and approved by the Jurisdiction.

2.01 TOPSOIL

Delete: “1 inch (1/2 inch for turfgrass seeding)” **and Replace with:** “3/8 inch”

2.04 FOUNDATION MATERIALS

D. Subbase:

1. Special Backfill:

Add: c. Recycled HMA (Hot Mix Asphalt) will not be allowed for special backfill under new PCC pavement.

3.04 EMBANKMENT CONSTRUCTION

C. Depositing Embankment Material:

1. **Add:** No embankments shall be built on frozen earth.

Add: F. Density Reports: Density reports shall be submitted to the Contractor and to the City within 3 days of the test being performed. No work shall progress until reports have been submitted, approved, and/or corrective action taken on deficient test results.

3.06 SUBGRADE PREPARATION

A. Uniform Composition:

4. **Add:** The City of Ames shall verify subgrade elevations prior to placement of subbase material.

Add: 5. A disk or plow shall be used for turning soil for drying. If conditions do not allow enough space for a disk or plow, the material shall be opened up for drying via other methods, proposed by the Contractor and with the approval of the Jurisdictional Engineer. Use of a ripper for turning soil will not be allowed.

B. Subgrade Stability:

1. **Delete:** "Perform proof rolling with a truck loaded to the maximum single legal axle gross weight of 20,000 pounds or the maximum tandem axle gross weight of 34,000 pounds." **and Replace with:** "Perform proof rolling with a tandem axel truck loaded with a minimum net weight of 15 tons of material. Proof rolling operations for verification of subgrade shall be jointly observed by the Contractor and City of Ames Staff." **Delete:** "or rutting of more than 2 inches, measured from the top to the bottom of the rut at the outside edges". **and Replace with:** "Tire rutting during proof rolling will be unacceptable."

2. **Delete and Replace with the following:** If soft or yielding areas are located, the Contractor shall provide subgrade preparation per 2010.3.06.A.2 and allow adequate time for the material to dry at no additional cost. Should the area fail the second proof rolling operations, a method of stabilization will be determined and agreed to jointly by the Engineer and the Contractor. The agreed stabilization method will be paid for utilizing existing contract items. If no appropriate contract items exist, the stabilization will be paid for by extra work order.

D. Subgrade Check:

Add: Contractor shall have survey stakes and string line set prior to performing the subgrade check. Contractor and City of Ames staff shall jointly verify subgrade elevations.

3.08 SUBBASE

D. Final Elevation:

2. **Add:** Contractor shall have survey stakes and string line set prior to performing the subbase check. Contractor and City of Ames staff shall jointly verify subbase elevations.

3.09 FIELD QUALITY CONTROL

B. Moisture Content and Density:

1. **Delete and Replace with the following:** Ensure that moisture content falls within a range of -1% to +3% of optimum moisture.

Division 3: Trench and Trenchless Construction

Section 3010: Trench Excavation and Backfill

1.08 MEASUREMENT AND PAYMENT

F. Trench Compaction Testing:

Delete and Replace with the following: The contractor will be responsible for compaction testing and retesting and all testing and retesting payments unless otherwise specified in the contract documents. Density reports shall be submitted to the Contractor and to the City within 3 days of the test being performed. Work shall not progress until reports have been submitted, approved, and/or corrective action taken on deficient test results.

2.01 MATERIALS EXCAVATED FROM A TRENCH

C. Over-excavation:

Add: No additional compensation will be made for minor adjustments to elevations due to field conditions.

3.05 PIPE BEDDING AND BACKFILL

A. General:

Add: 7. Pipe embedment shall be R-2 for storm sewer pipe, F-3 for sanitary sewer pipe, and P-1 for water main.

Add: F. Compaction: Compaction shall be achieved utilizing equipment as outlined in Iowa DOT Standard Specification Section 2001, General Equipment Requirements.

3.06 TRENCH COMPACTION TESTING

C. Field Testing:

2. Test Failure and Retesting:

Delete: "the Engineer may require retesting as deemed necessary." **and Replace with:** "submit all failed test results to the Jurisdiction."

Section 3020: Trenchless Construction

3.04 TRENCHLESS INSTALLATION

Add: E. Impact on Existing Sewers: For any installation by trenchless construction, the Contractor shall verify that sanitary and storm sewer main, including residential services, have not been impacted by the installation. The method of verification shall be either by visual inspection at critical crossings jointly with City staff, or by televising. If televising is used, the report shall be submitted to the City for review prior to acceptance and payment for the work and/or closure of the right-of-way permit. Any locations discovered to be in conflict shall be repaired immediately at no cost to the City.

Division 4: Sewers and Drains

Section 4010: Sanitary Sewers

2.01 SANITARY SEWER (Gravity Mains)

- A. Add:** This gravity sewer main material may be used only with approval of the Engineer.
- B. Add:** This gravity sewer main material may be used only with approval of the Engineer.
- C. Add:** This gravity sewer main material may be used only with approval of the Engineer.
- D. Add:** This gravity sewer main material may be used only with approval of the Engineer.
- H. Add:** This gravity sewer main material may be used only with approval of the Engineer.
- I. Add:** This gravity sewer main material may be used only with approval of the Engineer.
- J. Add:** This gravity sewer main material may be used only with approval of the Engineer.

2.04 SANITARY SEWER SERVICES

A. Connection to Main:

4. VCP Main:

a. **Delete and Replace with the following:** Replace the section of VCP from nearest joint to nearest joint or a minimum of 5 feet with truss type PVC or other pipe material approved by the Engineer. Install a wye or tee service fitting as specified for the pipe material used.

Delete: b.

3.02 GRAVITY SEWER INSTALLATION

A. General:

7. **Delete and Replace with the following:** Use a watertight stopper, plug, or other approved means to protect the exposed upstream ends of the pipe and prevent soil sediment from entering the sanitary sewer system.

Add: 8. Sewer main stubs shall extend at least one full length of pipe from a manhole structure.

B. Trenched:

3. **Add:** A pipe laser shall be used to verify line and grade.

3.06 SANITARY SEWER SERVICE STUBS

C.

5. **Delete:** “as required by the Jurisdiction or as specified in the contract documents.” **and Replace with:** “with a 14-foot long wood 2x4 that is painted green and wrapped with metallic tape, or as required by the Jurisdiction, or as specified in the contract documents.”

Section 4020: Storm Sewers

1.07 SPECIAL REQUIREMENTS

Add: Use Class R-2 Pipe Embedment from Figure 3010.102 (SW-102) for storm sewer pipe installations.

3.02 PIPE INSTALLATION

A. General:

3. **Delete:** “non-shrink grout or”

Section 4050: Pipe Rehabilitation

1.07 SPECIAL REQUIREMENTS

A. Add: Contractor shall coordinate with the City of Ames Water Meter Shop (515-239-5151) to determine the location of the water meter and all water meter requirements.

B. Delete: “Jurisdiction” **and Replace with:** “Contractor”

Section 4060: Cleaning, Inspection, and Testing of Sewers

2.01 TESTING EQUIPMENT

B. Video Inspection:

3. **Add:** Electronic files saved to a portable media device such as a flash drive are preferred by the City of Ames. Compact disc and DVD are acceptable but not preferred.

Add: 4. Video inspectors shall be NASSCO, PACP Certified.

3.01 CLEANING

A. **Delete:** “flushing with high pressure water” **and Replace with:** “jetting”

3.03 VIDEO INSPECTION

A. General:

Add: 5. All service taps shall be installed prior to video inspection.

Division 5: Water Mains and Appurtenances

Section 5010: Pipe and Fittings

1.08 MEASUREMENT AND PAYMENT

Delete: E.

2.04 CONCRETE THRUST BLOCKS

A. **Add:** Alternative concrete mixes or other materials may be used with approval of the Engineer.

2.05 PIPELINE ACCESSORIES

B. Tracer System:

1. Tracer Wire:

a. Open Cut:

2) Bimetallic Copper Clad Steel Conductor:

a) Size:

Delete and Replace with: #12 AWG

b. Directional Drilling/Boring:

1) Bimetallic Copper Clad Steel Conductor:

a) Size:

Delete and Replace with: #10 AWG

4. Splice Kit:

Delete and Replace with the following: Tracer wire splice kits shall be a 3M Direct Bury Splice (DBR/Y-6) or an equivalent system approved by the Engineer.

2.07 WATER SERVICE PIPE AND APPURTENANCES

B. Materials:

3. PVC Pipe:

Delete: “ASTM D 1785, Schedule 80 or ASTM D 2241, SDR 21.” **and Replace with:** “C900 with wall thickness of DR 14.”

3.01 PIPE INSTALLATION

A. General:

1. **Add:** “discolored,” **after** “use”

8. **Delete:** “when specified in the contract documents,”

10. **Delete:** “during nights and non-working days.” **and Replace with:** “immediately after individual pipe segments are installed in the trench.”

B. Trenched:

1. **Add:** Use P-1 Pipe Embedment from Figure 3010.104 (SW-104) for water main pipe installations. Granular material shall not be used for bedding or backfill material.

3.06 TRACER SYSTEM INSTALLATION

C. **Delete:** “lower quadrant” **and Replace with:** “top”

F. **Add:** “(looped)” **after** “wires”

Add: H. Use only bimetallic copper clad steel conductor during boring operations per 5010.2.05,1,B.

Add: I. At tapping valves or cut-in valve installations, tracer wire is to be installed along the outside of all valve boxes, inserted into a 2” minimum vertical slot located below the bottom of the valve box lid, and looped in a continuous fashion.

Add: J. Contractor to supply splice and grounding rod location documentation prior to connectivity testing.

3.07 CONFLICTS

C. Separation of Sewer and Water Main Crossovers:

Add: Comply with all Iowa Department of Natural Resource water main construction permit requirements.

2. **Add:** The water main shall be constructed of ductile iron pipe with nitrile gaskets extending at least 10 feet each side of the crossing.

3. **Add:** The water main shall be constructed of ductile iron pipe with nitrile gaskets extending at least 10 feet each side of the crossing.

Figure 5010.102 (WM-102)

Add to the end of the first sentence of Note 1: to maintain a continuous tracer wire run within the tracer wire system.

Section 5020: Valves, Fire Hydrants, and Appurtenances

1.08 MEASUREMENT AND PAYMENT

E. Valve Box Adjustment, Minor:

Add: Valve box adjustment rings will be incidental. Tracer wire connections, if present in the existing fixture, shall be restored incidental to any fixture adjustment.

F. Valve Box Extension:

1. Measurement:

Add: Tracer wire connections, if present in the existing fixture, shall be restored incidental to any fixture adjustment.

G. Valve Box Replacement:

3. Includes:

Add: Tracer wire connections, if present in the existing fixture, shall be restored incidental to any fixture adjustment.

I. Fire Hydrant Assembly Removal:

3. Includes:

Delete: “(if specified)”

J. Valve Removal:

3. Includes:

Delete: “(if specified)”

K. Valve Box Removal:

3. Includes:

Delete: “(if specified)”

2.01 VALVES

D. Tapping Valve Assemblies:

Add: 8. Thrust Blocks: Poured concrete reaction block meeting 5010.2.04 or mortared cap block shall be placed behind tapping valve sleeves for support. A maximum of 6 solid cap blocks (nominal 4”x 8”x 16”) may be used. Only full blocks shall be used, no breaking of the blocks will be allowed. No other material shall be used without approval of the Engineer.

2.02 FIRE HYDRANT ASSEMBLY

B. Manufacturers:

Add: Allowable new or replacement hydrants in the City of Ames: *Clow, Model: Medallion; Mueller: Super Centurion;* and *Waterous, Model: Pacer (WB-67-250).*

C. Features:

Delete: 6.

Add: 7. Operating Nut: Pentagonal, size 1.5 inches.

Add: 8. Pumper Nozzle: 5 inch, with a 4.5 inch Storz type hydrant converter and nut cap, AWWA compliant.

Add: 9. Nozzle Threads: National Standard.

Add: 10. Main Valve Nominal Opening Size: Match hydrant run pipe size.

Add: 11. Nominal Bury Length: 6 feet.

Add: 12. Minimum Height: 32 inches from top operating nut to bury depth mark.

D. Painting:

2. **Add:** Public hydrants shall be green in color: #2033 Hydrant Dark Green, silicone enamel, Klinger Paint Company, Cedar Rapids, Iowa.

2.03 APPURTENANCES

A. Flushing Device (Blowoff):

Delete and Replace with the following: Hydrants are required for blowoffs and for all 4” or larger water service stubs.

C. Valve Stem Extension:

Add: Valve stem extensions shall be a minimum 1" diameter solid steel shaft extension. Set screws on valve stem extensions are to be removed and not used for connection at the operating nut. Hollow shaft stems and stems with a roll pin at the bottom of the extension to allow pivoting of the stem at the valve will not be allowed.

Add: D. Holding Spools: Holding spools (minimum 12" long) are required between all valves and tees. No additional measurement or payment will be made.

3.03 FIRE HYDRANT

D. Fire Hydrant Depth Setting:

Add: 4. No more than one hydrant extension is allowed per hydrant.

3.04 ADJUSTMENT OF EXISTING VALVE BOX OR FIRE HYDRANT

A. Minor Valve Box Adjustment:

Add: Tracer wire connections, if present in existing fixture, shall be restored by placing a cut 1" below the lowest point on the valve box lid while the lid is inside of the valve box so as not to damage the tracer wire with the valve box lid and the valve box itself rubbing against each other.

B. Valve Box Extension:

Add: Tracer wire connections, if present in existing fixture, shall be restored by placing a cut 1" below the lowest point on the valve box lid while the lid is inside of the valve box so as not to damage the tracer wire with the valve box lid and the valve box itself rubbing against each other.

C. Valve Box Replacement:

Add: Tracer wire connections, if present in existing fixture, shall be restored by placing a 2" minimum vertical slot through valve box below the lowest point on the valve box lid while the lid is inside of the valve box so as not to damage the tracer wire with the valve box lid and the valve box itself rubbing against each other.

Figure 5020.201 (WM-201)

Add note: All pipe in the fire hydrant assembly shall be ductile iron, including the anchor pipe and riser pipe.

Add note: Unmixed dry concrete is not allowed for thrust blocks.

Section 5030: Testing and Disinfection

1.07 SPECIAL REQUIREMENTS

Add: Comply with the procedures and requirements stipulated in the supplemental document titled "City of Ames Water Main Disinfecting, Flushing, and Testing Using the Continuous-Feed Method".

3.05 PRESSURE AND LEAK TESTING

E. **Add:** All new fire hydrant assemblies 10 feet in length or greater shall be pressure tested.

I. **Delete and Replace with:** No leakage is allowed.

Delete: J.

Delete: K.

Division 6: Structures for Sanitary and Storm Sewers

Section 6010: Structures for Sanitary and Storm Sewers

2.02 PRECAST

Delete and Replace with the following: Unless specified, use of pre-cast structures, for storm sewer intakes in the City of Ames, will be allowed only with approval of the Engineer. Approved structures shall comply with ASTM C 478 and no additional compensation will be made for coring into the structure due to minor field adjustments of inlet and outlet pipes and subdrains.

2.03 CAST-IN-PLACE

A. Concrete:

Add: An M-4 concrete mix may be used for intake bases with approval of the Engineer.

2.09 MANHOLE OR INTAKE ADJUSTMENT RINGS (Grade Rings)

A. **Delete:** 1. Reinforced Concrete Adjustment Rings:

2. High Density Polyethylene Adjustment Rings:

Add: e. For use on storm sewer structures only.

3. Expanded Polypropylene Adjustment Rings:

Add: d. Shall be used for sanitary sewer manholes. Contractor has the option to also use for storm sewer structures.

2.10 CASTINGS (Ring, Cover, Grate, and Extensions)

D. Casting Types:

1. Manholes:

Add: Manhole castings shall be 2 piece fixed castings. Use of 3 piece casting for storm sewer manholes may be allowed with approval of the Engineer. For all manhole castings located in a flood plain, provide bolt down covers. All castings shall comply with figures SW-601 and SW-602. Concrete box outs for manholes in PCC paving shall comply with figure PV-103. Concrete box outs for manholes in HMA paving shall comply with figure PV-201. All manholes in paving shall be gasketed.

Table 6010.03: Manhole Casting Types

Footnote 2: **Delete:** “may” **and Replace with:** “shall”

2. Intakes:

b. **Delete:** “may” **and Replace with:** “shall”

2.11 ADDITIONAL MATERIALS FOR SANITARY SEWER MANHOLES

B. Riser Section Coating:

1. Exterior:

Delete and Replace with the following: All sanitary sewer manholes shall have bituminous waterproofing on all exterior concrete surfaces.

Delete: 2.13 STEPS (Steps are not allowed.)

3.02 ADDITIONAL REQUIREMENTS FOR CAST-IN-PLACE CONCRETE STRUCTURES

A. Forms:

2. Add: On intake replacement projects the Jurisdictional Engineer may allow the exterior walls of the intake to be poured against undisturbed earth where the vertical face is true, and the wall thickness will not exceed 8 inches in width.

3.05 CONNECTION TO EXISTING MANHOLE OR INTAKE

C. Sanitary Sewer:

1. General:

Add: c. All connections shall be inspected by City of Ames staff prior to acceptance.

2. Cored Opening:

a. **Add:** Connector shall be “Link-Seal” modular type or approved equal.

Delete: 3. Cut and Chipped Opening (Knock-out):

D. Storm Sewer:

1. Delete: “and Chipped”

Delete: a.

2. Cored Opening:

Delete: a.

Figure SW-514

Delete: Sheet 3 (Not allowed in the City of Ames.)

Division 7: Streets and Related Work

Section 7010: Portland Cement Concrete Pavement

1.07 SPECIAL REQUIREMENTS

Add: A. Fixtures: When placing PCC, the Contractor shall protect adjacent fixtures from concrete splatter or direct contact with the concrete. Fixtures include, but are not limited to, light poles, light pole bases, controller cabinets, hand holes, buildings, manhole lids, water valve lids, and fire hydrants.

Add: B. Maturity Testing: If a valid maturity strength curve is not available for the concrete mix provided, a C4 mix shall be used with a minimum of 5 days cure prior to opening for sealing operations. The contractor, at their option, may hire an independent testing company to make, cure, and test flexural strength specimens in accordance with IDOT IM 316 to verify the pavement meets opening strength requirements should they wish to shorten the minimum cure time, at no additional cost to the City.

3.02 PAVEMENT CONSTRUCTION

F. Concrete Pavement Placement:

1. Delete and Replace with the following: Use a slip-form paving machine for all pavement 8.5 feet or more in width and 150 feet or more in length. For pavement sections less than 8.5 feet in width and/or less than 150 feet in length, screed finish methods may be used.

Add: 10. Minimum Pavement Thickness Table:

Minimum PCC Pavement Thickness			
Street Classification	Pavement Thickness		
	Commercial / Industrial	Residential / Fringe	Rural
Local (on grade) (1)	8" (7" Reinforced)	8" (7" Reinforced)	8" (7" Reinforced)
Local (on minimum 6" subbase)	7"	7"	7"
Minor Collector (1)	8"	8"	8"
Major Collector	Special Design (See SUDAS Design Manual Section 5F)		
Minor/Major Arterial	Special Design (See SUDAS Design Manual Section 5F)		

(1) Load Transfer Devices Required

M. Pavement Backfill:

Add: "or slipform curb and gutter" **after "paving"**

3.03 CURB AND GUTTER CONSTRUCTION

A. **Add:** Construct curb and gutter as per the City of Ames curb standard with 30" width and heights of 7" at the face and 12" at the back with a 1" tilt onto curb. An 'ED' Joint is required at each end of a radius.

B. **Delete and Replace with the following:** Use a paving machine for curb and gutter sections 150 feet or more in length. For curb and gutter sections less than 150 feet in length, hand placement/finish methods may be used.

Add: C. No asphalt shall be placed against curb less than 72 hours old unless maturity testing of the curb has been successfully completed in accordance with IDOT IM 383 or flexural strength testing has been successfully completed in accordance with IDOT IM 316. All testing shall be done by the contractor and witnessed by City staff for verification.

Add: D. All curb and gutter shall be backfilled prior to placement of any adjacent pavement.

3.07 QUALITY CONTROL

C. Pavement Smoothness:

1. Straightedge:

Delete: "The Engineer will check PCC pavement surfaces with a 10 foot straightedge placed parallel to the centerline." **and**

Replace with: "The Contractor will check PCC pavement surfaces in the presence of City staff with a 10 foot straight edge or "bump buggy" placed parallel to the centerline."

Figure 7010.102 (PV-102)

Delete: the 6" standard curb detail. (See the City of Ames curb detail below.)

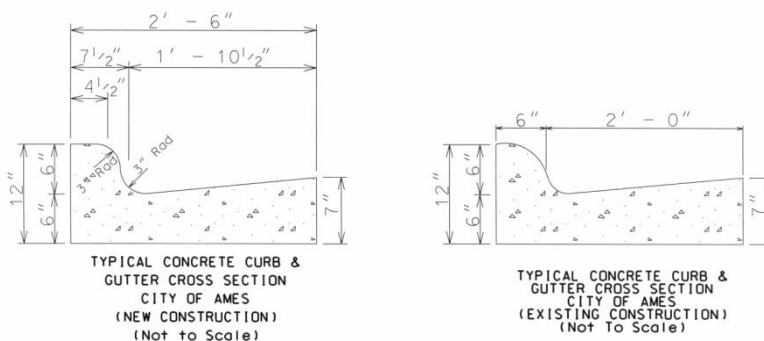

Section 7011: Portland Cement Concrete Overlays

1.08 MEASUREMENT AND PAYMENT

A. PCC Overlays:

1. PCC Overlay, Furnish Only:

c. Includes:

Delete and Replace with the following: Unit price includes the PCC furnished and incorporated into the PCC overlay.

Section 7020: Hot Mix Asphalt Pavement

1.07 SPECIAL REQUIREMENTS

Add: A. HMA surface placement in subdivisions shall be delayed a minimum of one calendar year from the final date of HMA base placement.

Add: B. HMA surface placement in subdivisions shall not take place in the fall season after the date of October 15th without the approval of the Engineer.

3.01 HMA PAVEMENT

H. Minimum Pavement Thickness Table:

Minimum HMA Pavement Thickness									
Street Classification	Surface Course Thickness			Intermediate/Base Course Thickness			Total Pavement Thickness including Surface Course		
	C/I	Res	Rural	C/I	Res	Rural	C/I	Res	Rural
Local	2"	2"	2"	7"	6"	7"	9"	8"	9"
Minor Collector	2"	2"	2"	8"	7"	7"	10"	9"	9"
Major Collector	Special Design (See SUDAS Design Manual Section 5F)								
Minor / Major Arterial	Special Design (See SUDAS Design Manual Section 5F)								

C/I = Commercial/Industrial at 5% Trucks

Intermediate/Base Course Thickness may be reduced 1” for every 6” of subbase material placed for up to 12” of subbase material.

3.02 BASE WIDENING

D. Construction:

2. Delete “4 1/2” and Replace with: “4”

3.05 PAVEMENT SMOOTHNESS

A. Straightedge:

Delete: “The Engineer will check HMA pavement surfaces with a 10 foot straightedge placed parallel to the centerline.”

and Replace with: “The Contractor will check HMA pavement surfaces in the presence of City staff with a 10 foot straight edge or “bump buggy” placed parallel to the centerline.”

Section 7030: Sidewalks, Shared Use Paths, and Driveways

1.07 SPECIAL REQUIREMENTS

Add: A. S-Sheets: Design elements for curb ramps to be shown on City approved “S-Sheets” similar to those utilized by the Iowa DOT.

Add: B. Pedestrian Facility Construction: Pedestrian facilities shall be installed in conjunction with street and curb and gutter improvements and verified per Section 7030.3.04.G. Acceptance of street and curb and gutter improvements will not be granted if this condition is not met.

Add: C. Pedestrian Facility Curb Drops: Grinding or cutting pedestrian facility curb drops is not permitted. Where pedestrian facility curb drops are required, the PCC curb and gutter shall be new construction or removed and replaced.

2.01 PORTLAND CEMENT CONCRETE

A. **Delete:** “B or”

B. **Table 7030.01: PCC Mixes**

Delete: “B or”

2.07 DETECTABLE WARNINGS

Delete and Replace with the following: Detectable warning panels (truncated domes) shall be TufTile 10 GA. Galvanized Steel with Brick Red Powder Coat (Federal Color 22144)

3.04 PCC SIDEWALKS, SHARED USE PATHS, AND DRIVEWAYS

F. Jointing:

2. **Transverse Contraction Joints:**

b. **Sidewalks and Driveways:**

3) **Delete and Replace with the following:** Transverse contraction joints shall be sawed within 12 hours of placement with a 1/8 inch blade saw from edge to edge.

4. **Isolation Joints:**

c. **Add:** Isolation joints shall be sealed, including joints that abut the back of curb.

Add: G. Pedestrian Facility Compliance and Acceptance:

1. General: The contractor is responsible for constructing all new pedestrian facilities in accordance with the plans, specifications, and applicable standards. Pedestrian facilities include sidewalks, shared use paths, pedestrian ramps, and crosswalks.

a. City and Subdivision Projects:

1) Upon request, the engineer can provide assistance and guidance on plan interpretation. However, the contractor is solely responsible for implementing the plans.

2) The design and construction parameters of pedestrian ramps are relatively narrow. Minor errors in formwork or pavement finishes can significantly affect the final results. Because of this, special care and attention should be taken when setting formwork and/or finishing the various elements of pedestrian ramps including, but not limited to, adjacent curb and gutter, ramp lip, truncated dome placement, widths, running slopes, and cross slopes.

3) A pay-item for Pedestrian Facility Construction Survey and Staking has been added to account for the anticipated extra effort to comply with the strict standards of all City of Ames projects. No extra payment for this item will be made.

4) The Contractor installing the pedestrian facilities shall have a set of construction plans on site.

b. Private Construction and Private Utility Projects:

1) The design of the affected facility shall be done by the project owner's engineer.

2) Upon request, the project owner's engineer can provide assistance and guidance on plan interpretation. However, the contractor is solely responsible for implementing the plans.

2. Payment: No payment will be made for pedestrian facilities as described in Section 21.1 until the pedestrian facility compliance with the approved plan is verified by the Engineer.

3. Review: Initial review of Pedestrian Facility plan compliance will be made by the Engineer no more than 5 business days after the Contractor reports to the Engineer that the entire shared use path section, sidewalk section, crosswalk section, or pedestrian ramp is complete. Partial acceptance of pedestrian facilities will not be made. (i.e. 6" sidewalk ramp and landing pad will not be accepted until 4" sidewalk tie-ins are completed and ALL elements of the pedestrian ramp are determined compliant.)

4. Determining Compliance: Plan compliance of pedestrian facilities will be determined by the Engineer via the use of a smart level. Measurement will take place after construction and shall be within the tolerances called out in the plans. If any element falls outside the specified tolerances, the pedestrian facility will be determined non-compliant. The contractor shall remove and replace all non-compliant elements and any additional items including, but not limited to, newly placed curb and gutter, as necessary in order to bring the pedestrian facility into compliance at no cost to the City.

a. In the event the contractor does not agree with the Engineer, they can present their own information at no additional cost to the City. This may be in the format of using another, properly calibrated smart level in the presence of the Engineer, or through the use of a total station. No GPS verification will be allowed. The Engineer will respond to the additional information provided by the contractor within 5 business days.

b. If the contractor presents data confirming non-compliance, the contractor shall remove and replace the pedestrian facility at no cost to the City.

c. If the contractor presents data confirming they are in compliance, and the City accepts that data, the Engineer will determine the pedestrian facility is within compliance.

d. If the contractor presents data showing they are in compliance, and the City has cause to believe the data may be in error, the City will re-evaluate the pedestrian facility. The City will then provide written documentation of the survey data, possible concerns, and required action if any are necessary for final acceptance.

5. 3rd Party Survey: In the event the contractor has cause to believe the City is in error after Section 7030.3.04.G.4, a third party survey can be requested, in writing, by the contractor. The City will then hire a third party surveyor to verify the newly constructed pedestrian facility via the use of a total station.

a. By requesting this, the contractor is agreeing to pay the third party surveyor fees through a change order of the contract if the pedestrian facility is determined out of compliance. The contractor also agrees to remove and replace any non-compliant pedestrian facility at no cost to the City.

b. If the pedestrian facility is determined to be compliant, the contractor will not be charged for any of the third party survey work and the pedestrian facility will be determined compliant by the Engineer.

6. As-Built Drawings: Once compliance of the pedestrian facility has been verified and accepted, the Contractor shall provide the Engineer with as-built drawings for each verified and accepted location. The as-built will include, but is not limited to, distances and slopes within the facility.

3.10 CLEANING

Add: D. Prior to opening the sidewalks and pedestrian crossings, the Contractor shall clean the detectable warning panels of all superfluous concrete and remove the plastic covering after the concrete is cured such that the panel surface is clean and the truncated surface is fully functional.

Figure 7030.101

Add note: Driveway curb opening widths for new pavement shall conform to Table 5I-4.01 of the SUDAS Design Manual. Expansion material shall be fiber board with a total of 1" of total expansion between the back of curb and either edge of the sidewalk (i.e. 1" at back of curb, none at edge of sidewalk **OR** none at back of curb and 1" at edge of sidewalk **OR** ½" at back of curb and ½" at edge of sidewalk).

Delete: Figure 7030.102 Application of this detail shall not be used in the City of Ames. Integral driveways are not allowed without approval of the Jurisdictional Engineer.

Figure 7030.204

Add note: All ramp to pavement connections shall be BT-3 joints.

Figure 7030.205

Add note: All ramp to pavement connections shall be BT-3 joints.

Figure 7030.206

Add note: All ramp to pavement connections shall be BT-3 joints.

Figure 7030.207

Add note: All ramp to pavement connections shall be BT-3 joints.

Section 7040: Pavement Rehabilitation

1.08 MEASUREMENT AND PAYMENT

C. Partial Depth Patches:

4. Extra Payment:

Delete and Replace with the following: When partial depth patches are constructed to full depth at the direction of the Engineer, payment will be at the contract unit price for full depth patches or at the unit price negotiated via change order.

Division 8: Traffic Control

Section 8010: Traffic Signals

2.01 UNDERGROUND

A. Handhole:

1. General:

Add: d. No additional handholes are to be installed during construction unless approved by the Jurisdictional Engineer.

3. Composite Handhole and Cover:

Add: The final handhole before entering the controller cabinet shall be a 30 inch by 48 inch by 24 inch deep heavy duty QUAZITE® style enclosure, box identification #PG3048BA24, and shall have a Heavy Duty 2-Piece cover with 2 bolts set, cover identification #PG3048HS00, or approved equivalent box and cover.

B. Conduit:

Delete: 2. Steel Conduit and Fittings: (No rigid steel conduit is to be used in the City of Ames.)

C. Wiring and Cable:

2. Signal Cable:

Delete and Replace with the following: Signal Cable shall be multi-conductor copper wire, and meet the requirements of IMSA Specification 19-1. All Signal Cable shall be stranded 14 A.W.G. wire. All splices to IMSA Specification 19-1 cable must be done using moisture resistant Scotchlok 314 type connector or an approved equivalent.

4. Communications Cable:

Add: All splices to communication cable shall be done using moisture resistant Scotchlok UR2 type connectors or an approved equivalent.

2.02 DETECTION

Add: Type and Model of pedestrian and vehicular detection shall be specified or submitted and approved by the Jurisdictional Engineer.

2.03 COMMUNICATIONS

Add: Type and Model of pedestrian and vehicular signal communication shall be specified or submitted and approved by the Jurisdictional Engineer.

2.04 CABINET AND CONTROLLER

Add: Type and Model of pedestrian and vehicular cabinets and controllers shall be specified or submitted and approved by the Jurisdictional Engineer.

2.05 POLES, HEADS, AND SIGNS

Add: Type and Model of pedestrian and vehicular poles, heads, and signs shall be specified or submitted and approved by the Jurisdictional Engineer.

Figure 8010.104

Delete: The Rectangular Detector Loop detail. (This style of inductive loop vehicle detectors shall not be used in the City of Ames.)

Delete: The Section A-A detail **and Replace with:** Section A-A from the Modified Diamond Detector Loop Figure 8010.19 shown below:

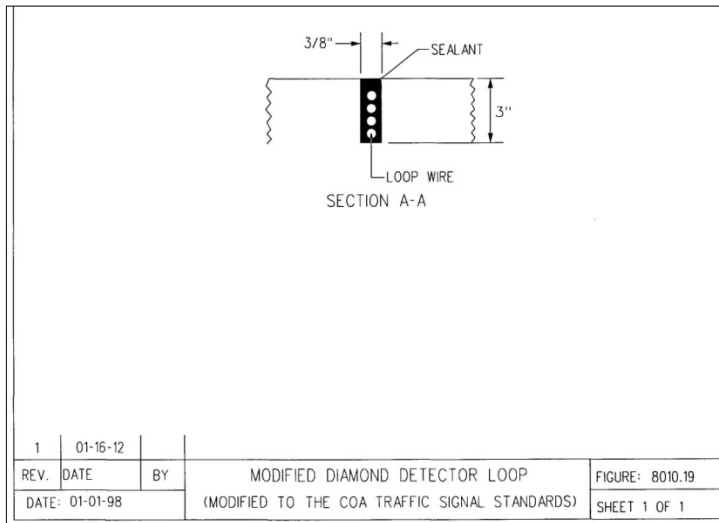

Section 8020: Pavement Markings

2.01 MATERIALS

B. Pavement marking materials include:

Add: 11. Preformed thermoplastic.

3.02 CONSTRUCTION

B. Surface Preparation:

Add: 5. Contractor shall use a high-pressure water system (water blasting) for cleaning, unless the air temperature is 32 degrees (freezing point) or below. If the air temperature is below the freezing point, then surface grooving per 8020.3.02.J may be allowed with approval of the Engineer. Payment shall be per station (100 LF) of finished markings.

Add: 6. Removal of existing pavement markings may be by vacuum blasting, shot blasting, or high pressure water blasting. Open abrasive blasting without containment will not be allowed. The equipment and method used shall be recommended by the manufacturer. Pavement grinding or grooving for removal of pavement markings, symbols, or legends will not be allowed without prior approval of the Engineer.

C. Painted Pavement Markings:

Add: Pavement markings shall be grooved, high-build waterborne paint pavement markings unless otherwise approved by the Engineer. Pavement markings installed outside of grooves shall be removed via water blasting and reinstalled within the grooves at the Contractor's expense. If waterborne or solvent based paint is allowed, longitudinal pavement markings on HMA (Hot Mix Asphalt) shall be applied in two passes, with beads spread during the second pass. The second pass shall be laid no sooner than two hours after the first pass. HMA pavement shall be clean and free of all debris prior to painting. Payment shall be per station (100 LF) of finished markings, regardless of the number of paint passes.

Add: L. Symbols and Legends: Symbols and legends shall be thermoplastic unless otherwise approved by the Engineer. Symbols and legends shall be grooved into the pavement per 8020.3.02.J. Pavement shall be cleaned and free of all debris prior to placing symbols as per 8020.3.02.B. Payment shall be per each symbol.

Section 8030: Temporary Traffic Control

1.03 SUBMITTALS

A. Delete and Replace with the following: Traffic control plans shall be submitted at least 48 hours in advance, that includes stages/phasing for approval by the Engineer. This is subject to change for emergency situations.

B. Add: “48 hours” **after** “approval”

3.01 INSTALLATION

B. Sign Posts

Add: The Engineer has the discretion to waive this requirement, upon specific request.

3.03 QUALITY CONTROL

A. Traffic Control Technician:

Add: The Engineer has the discretion to waive this requirement, upon specific request.

B. Monitoring and Documentation:

5.

Add: The Engineer has the discretion to waive the traffic control diary requirement, upon specific request.

Division 9: Site Work and Landscaping

Section 9010: Seeding

1.03 SUBMITTALS

Add: C. At the pre-construction meeting and/or prior to any contract work commencing, submit a written watering plan detailing the equipment to be used, the water source, and the manpower to be used towards meeting the specified watering requirements.

1.08 MEASUREMENT AND PAYMENT

A. Conventional Seeding:

1. Seeding:

a. Measurement:

Add: If construction limits or easement limits are not defined in the contract documents, the jurisdictional engineer shall determine the limits of measurement for pay.

3.04 CONVENTIONAL SEEDING

C. Seedbed Preparation, Permanent:

2. Delete “3 inches.” **and Replace with:** “6 inches.”

D. Seedbed Preparation, Temporary:

Delete “5 inches” **and Replace with:** “6 inches”

3.05 HYDRAULIC SEEDING

D. Seed Application, Fertilizing, and Mulching:

3. Add: “or other approved water source” **prior to** “using”

Section 9020: Sodding

1.03 SUBMITTALS

Add: D. At the pre-construction meeting and/or prior to any contract work commencing, submit a written watering plan detailing the equipment to be used, the water source, and the manpower to be used towards meeting the specified watering requirements.

1.08 MEASUREMENT AND PAYMENT

A. Sod:

1. Measurement:

Add: If construction limits or easement limits are not defined in the contract documents, the jurisdictional engineer shall determine the limits of measurement for pay.

3.01 PREPARATION OF SODBED

D. Delete: “depth of 3 inches.” **and Replace with:** “depth of 6 inches.”

Section 9030: Plant Material and Planting

1.03 SUBMITTALS

Add: F. At the pre-construction meeting and/or prior to any contract work commencing, submit a written watering plan detailing the equipment to be used, the water source, and the manpower to be used towards meeting the specified watering requirements.

Section 9040: Erosion and Sediment Control

1.08 MEASUREMENT AND PAYMENT

D. Filter Socks:

1. Installation:

b. Payment:

Add: “excluding any overlap.” **to the end of the sentence**

2. Removal:

b. Payment:

Add: “excluding any overlap.” **to the end of the sentence**

2.18 INLET PROTECTION

A. Drop-in Intake Protection:

Add: 4. Below grate inlet protection shall be installed as soon as possible after streets are paved.

Delete: **B. Surface-applied Intake Protection:** (Surface-applied intake protection shall not be used in the City of Ames.)

3.05 COMPOST BLANKETS

A. Delete and Replace with: When placed in conjunction with seeding, loosen the ground surface to a depth of 6 inches.

3.09 WATTLES

A. Installation:

6. Add: Installation per IDOT Figure EC-204 is also acceptable.

Division 11: Miscellaneous

Section 11,050: Concrete Washout

2.01 CONCRETE WASHOUT

C. Prohibited Products:

Add: “Unlined” **prior to “silt fence”**