

JANUARY 2024

MONTHLY PROJECT HIGHLIGHTS



Report compiled by
Jeremy Neefus, Principal Clerk
City Manager's Office

Contact the City Manager's Office at 515-239-5101



515 Clark Avenue, Ames, IA 50010



LIBRARY

Black History Month: Ames Public Library is celebrating Black History Month in February with special events and displays.

Children and families are invited to learn about African American history through music with the African American Museum of Iowa's presentation of "Behind the Beat" Monday, February 12, at 2:00 p.m. at the Library.

On Tuesday, February 20, at 6:00 p.m. Basi Affia will present "The Power of Storytelling." Basi will share how he found power by bringing representation to the science fiction and fantasy genres through Sensiil Studios, Iowa's first black comic book publisher. Artwork from Sensiil Studios' publications will be on display in the Library's vestibule through February.



Watch for Ames Public Library's upcoming Black Arts Festival on April 20, 2024!

A colorful flyer for a "BABY FAIR" event. The flyer features a baby sitting on a blue cloud, the Ames Public Library logo, and text about the event on February 17, 2024. It also includes a list of topics: Pregnancy, Birth, Postpartum, and Early years, with a "AND MORE!" callout.

Connecting Families to Resources: Libraries connect people to books and information, but they also connect their community to local resources.

On Saturday, February 17, Ames Public Library will host a Baby Fair from 10:00 a.m. – 12:00 p.m., where community members can meet professionals and community partners related to pregnancy, birth, postpartum, and children's health.

Parents and parents-to-be are also welcome at a Parenting Circle at the Library on the 2nd Friday and 4th Saturday of each month at 9:30 a.m.

Families looking for summer activities are invited to a Summer Camp Fair on Saturday, March 2, from 10:00 a.m. until 1:00 p.m. at the Library. Exhibitors will share information about

summer camps, programs, and activities in Ames and the surrounding area.

Staff Training Day at the Library: Ames Public Library will be closed on Presidents' Day, Monday, February 19, to allow all staff to gather for training, information sharing, and Strategic Plan activities.

PARKS AND RECREATION

Ames/ISU Ice Arena: The Ames/ISU Ice Arena was busy during the month of January with public skates, birthday parties, ice rentals, and programs. Public skates averaged 82 skaters, with the busiest public skate having 223 attendees. The Ames/ISU Ice Arena hosted nine birthday



parties, two Iowa State University (ISU) Men's hockey games, six Ames Minor Hockey Association (AMHA) high school games, two ISU Women's games, and two private rentals. The Ames/ISU Ice Arena also hosted an Ice Resurfacer Experience, a Destination Storytime in partnership with the Ames Public Library, two pickup hockey games, and a curling bonspiel (tournament).

Looking ahead, two exciting events are coming up: Great to Skate on February 10 and Try Sled Hockey for Free Day on April 21. Great to Skate is made possible through a US Figure Skating grant and will feature informational booths (Ames Figure Skating Club, AMHA, and ISU

Hockey), skate with a hockey player, and mini skating lessons. Try Sled Hockey for Free Day will feature demonstrations by participants of the Adaptive Sports Iowa Sled Hockey Program and an opportunity for individuals to try the sport.

Aquatics: Winter swim lessons began January 7 at ISU Forker Pool with a total of 123 registrants. The spring session of swim lessons will begin on February 13. The spring session will be the final session of swim lessons that will be held at ISU Forker Pool, as it is scheduled to close at the conclusion of the Spring 2024 semester. Staff has started conversations with other indoor pools within the community to potentially utilize for swim lessons, certification classes, and staff trainings outside the Furman Aquatic Center season.

Parks and Recreation hosted a Red Cross Babysitter's Training Course. The class is offered to youth ages 11+ and provides those planning to babysit with the knowledge and skills necessary to care for children and infants safely and responsibly. A total of six individuals participated.

A Lifeguard Training Course was offered December 1-3, certifying five new lifeguards. The Red Cross is releasing a new lifeguard class curriculum in February. Once staff is trained on the new curriculum, more classes will be offered.

Parks and Recreation partnered with ISU Recreation Services to offer a Water Safety Instructor Course (WSI) January 6-11 at ISU State Pool. This course trains instructor candidates to teach all

the courses presented in the Swimming and Water Safety program to all age groups. A total of six City staff members participated and were certified through this course.

Hiring for the 2024 Furman Aquatic Center season has already begun! Parks and Recreation has incorporated new hiring events to provide a one-stop process for interested candidates to apply, interview, and complete the required lifeguard prerequisite swim test. The first event was held on January 21 at ISU Forker Pool. Future aquatics-specific hiring events will be held on February 4 (5:30 - 7:30 p.m.), March 10 (11:00 a.m. - 1:00 p.m.), and April 6 (5:30 - 7:30 p.m.) at ISU Forker Pool.

Cross Country Ski Clinic: Parks and Recreation held another successful free Cross-Country Ski Clinic with 42 total registrations this year, compared to 28 in 2023. The clinic's indoor session was held January 13 with instructors Tim Gartin and Greg Welk educating participants on the history of cross-country skiing, proper equipment, and different techniques. Due to inclement weather, the outdoor session at Carr Park took place January 20, where the instructors took participants to the groomed ski trails to practice and hone their skills. Thank you to instructors Greg Welk and Tim Gartin and to ski equipment rental partners Jax Outdoor Gear and ISU Recreational Services.



Forestry: Parks and Recreation crews removed volunteer trees that were growing through and around the fence line on the south side of the CBD lots, including the removal of two dead trees south of Wells Fargo Bank.

The City allows residents to drop off their Christmas trees for recycling. Staff chips the trees and the mulch is made available to residents at no cost.

Once or twice per year, a contractor is hired to grind the tree debris accumulated from City tree work. In January, the contractor began grinding the wood debris pile south of the Park Maintenance Building, 700 E 13th Street, and will truck the wood chips off site.



Parks and Recreation has a tree trimming and inspection plan whereby every park and Right-of-Way (ROW) tree is inspected and pruned, if needed, every five years. In January, the following areas have been completed:

Park or ROW Zone	Number of Trees Pruned
Daley Park	197
Stuart Smith Park	119
ROW Zone 17	387
ROW Zone 5	869

Staff removed approximately 35 dead ash trees from the ROW ditch between Grand Avenue and Dawes Drive. The trees were posing a hazard and needed to be removed.



Hiring Tailgate: Parks and Recreation will hold its second annual Hiring Tailgate on February 24 at the Homewood Golf Course Clubhouse. The event will take place from 9:00 a.m. - 12:00 p.m. with food, games, and prizes. This is a great opportunity for the public to learn about job opportunities available through Parks and Recreation, meet staff, ask questions, discuss the hiring process, and complete an online application.

Homewood Golf Course: New sessions of euchre and cribbage started at Homewood Clubhouse. Euchre has 24 participants on 12 teams; morning cribbage has nine participants; and evening cribbage has 14 participants.

Below is a chart with the current Clubhouse rental hours and revenue amounts compared to the same time frame last fiscal year.

	July 1, 2022 – January 26, 2023	July 1, 2023 – January 26, 2024
Paid Event Hours	99.75	89.75
Revenue from Paid Events	\$9,875	\$9,285
Non-Paid Events Hours	84.75	98.25

Steven L. Schainker Plaza: Henkel Construction, LLC., Ames, Iowa, has been hampered by snow events that took place in January; however, the concrete for the ice-skating ribbon that was poured in December passed all curing requirements in early January. The spray pad contractor completed stubbing in all the piping and electrical conduit for the spray pad. Given the snow and cold temperatures, Henkel has focused its efforts on preparing the interior of the restroom/mechanical building for installation of the concrete floor. Work to be completed in February includes the concrete floor in the restroom/mechanical building as well as the installation of the ice making chiller and condensing unit. The image to the right shows the progress on the restroom/mechanical building interior. Photos on the next page show the progress on the ice skating ribbon and on water lines for the spray pad.

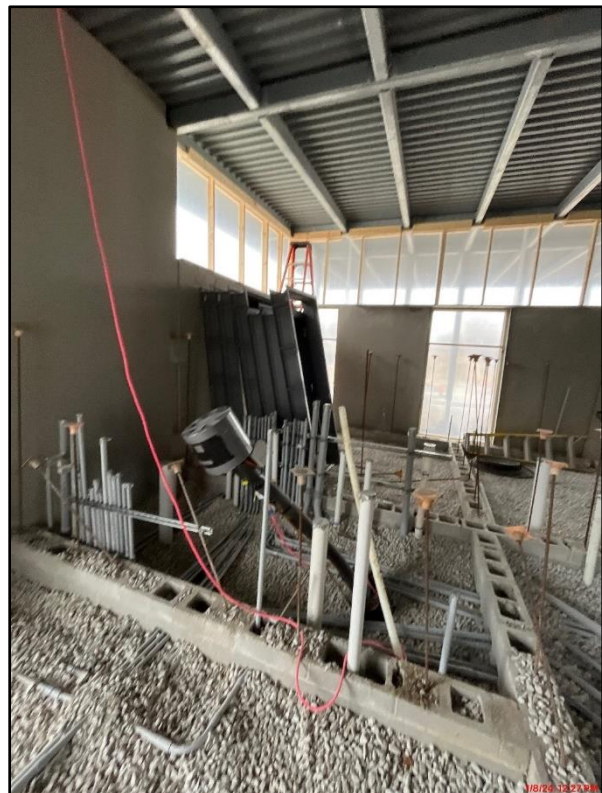



Wellness: Parks and Recreation offered 24 free classes over the holiday break with approximately 274 people attending and donating non-perishable food items to Food at First.

Several wellness classes began in January with the following registrations:

Program	Registrations
Group Fitness	
• In-Person Registrations	471
• Virtual Registrations	32
Taekwondo	123
Aqua Classes at Forker	82
West Coast Swing Dance (Beginner)	11

The annual Taekwondo potluck and awards banquet was held on Sunday, January 7, with over 100 people attending.



TRANSIT

B100 Pilot Project: Work has begun to implement the B100 pilot project on five 40' diesel buses. Optimus Technologies had an engineering team onsite the week of January 8 to take measurements in preparation for ordering parts and upfitting the buses. CyRide has also been notified that the fuel storage tank has been assembled and is ready for installation once a final vehicle installation date is determined, which is expected to be in early summer.

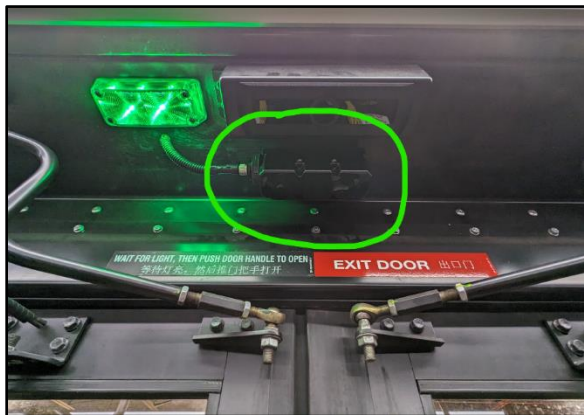
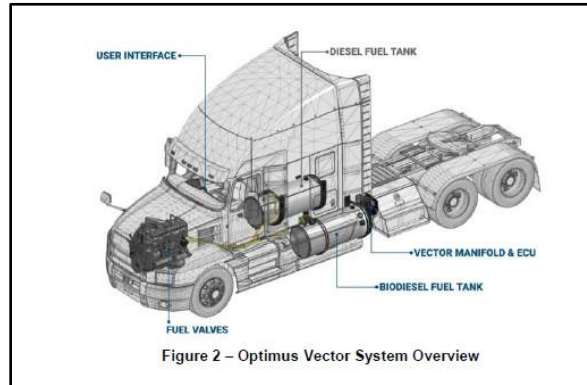

Installation of Sensors: As part of its commitment to continuous improvement, CyRide recently upgraded all low-floor buses equipped with touch bar handles on the rear doors to include a sensor that detects when passengers wave their hands. This change will make it easier for passengers to operate the back doors and reduce the potential for the doors to unexpectedly close when riders are deboarding. The Technology Coordinator and the maintenance division developed a custom circuit board to

utilize a less specialized sensor product for this purpose, and the maintenance division tested and installed the sensors. This project is an excellent example of multiple divisions within CyRide pooling their creativity and innovation to provide a low-cost solution to an ongoing issue.

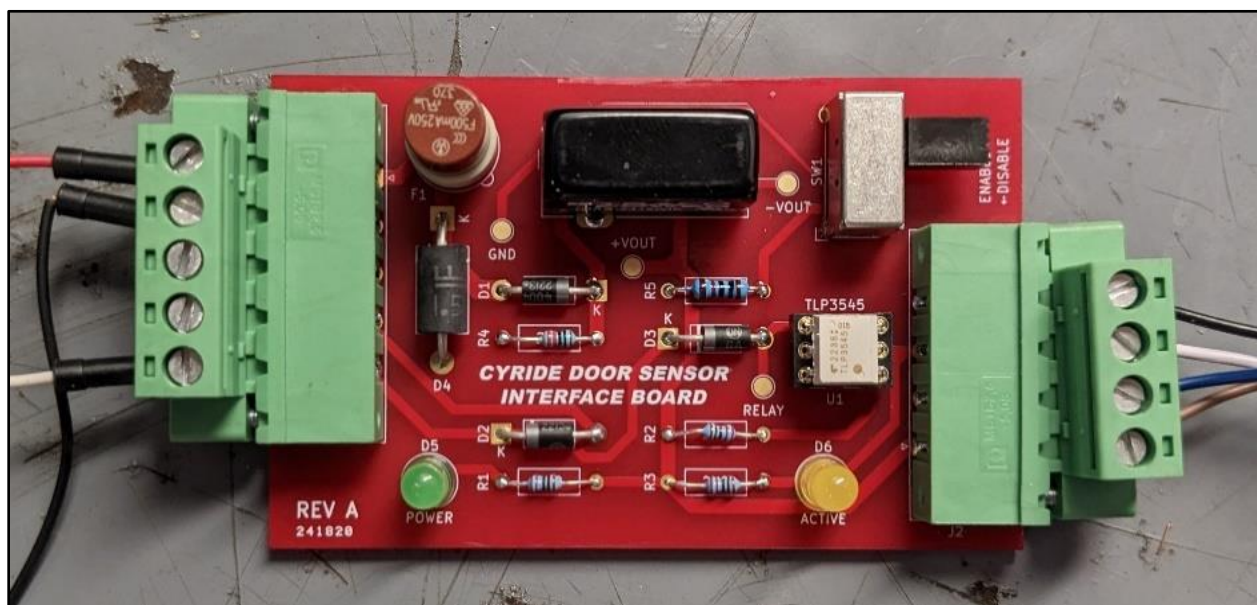

Security System Upgrade: At the January Transit Board Meeting, the board approved an award of contract for CyRide's Security System Upgrade Phase II. The plans and specifications for this upgrade include improvements in facility visibility, intrusion detection, and expansion of electronic access controls. The design also integrates with the security system recently deployed at City Hall, which will reduce costs, allow centralized system maintenance, and increase security coordination between CyRide and other departments. The contract was awarded to Commonwealth Electric of the Midwest of Des Moines, Iowa. The bidder's proposal was determined to be fair and reasonable, and the company demonstrated a good understanding of the project's scope of work. The company was also involved in City Hall's security project and has the knowledge base to competently integrate the two systems. CyRide looks forward to moving ahead with its goal of improving security in the facility. The City Council approved the award of contract at its meeting on January 23.